

MX - GG PUMP RANGE

Everyvalve

CHEMICAL PUMPING SOLUTIONS

END SUCTION, HORIZONTAL, **MAGNETIC DRIVE**, CENTRIFUGAL PUMPS



- ∞ CAPACITY <800L/MIN
- ∞ HEAD <35 Metres
- ∞ RUN DRY TECHNOLOGY
- ∞ POLYPROPYLENE / EFTE BUILD
- ∞ TOTAL CORROSION RESISTANCE
- ∞ EX-STOCK AVAILABILITY
- ∞ OVER 70% OPERATING EFFICIENCY

Part of the
MAGNETIC DRIVE
Pump Range



M



MX



VF



MA



ME

∞ MX-GG OVERVIEW

Magnetically driven pumps are the industry standard when processing harsh and highly corrosive applications. The centrifugal force is driven by two rotating magnets rather than being directly coupled to a motor. Eliminating the need for a mechanical seal and therefore making magnetic drive pumps completely leak proof.

The MX-GG range of magnetic drive pumps are designed to provide you with a long service life and minimal running costs. Operating at over 70% efficiency, AMX-GG pumps can be relied upon to work in the toughest of conditions including high corrosion, temperature and ATEX zones.

∞ REDUCED LIFE CYCLE COST

The patented run dry technology built into the MX helps protect your pumps from a failure in the process. Most mechanically sealed pumps will fail when run dry, causing dangerous leakages and costly clean up bills as a result. However with the MX, the pump can run dry for a number of hours alleviating process problems and avoiding damage to the pump.

The second patented design feature of the MX range will increase the mean time between servicing, reducing overall maintenance costs of your process. Should the MX pump be subjected to adverse operating conditions, vibration would normally reduce the life of the internal parts. However, with the dynamic buffer system acting as a shock absorber between the impeller and the casing, the pump is protected as a result, thus minimalising wear and prolonging the pumps service life.

∞ HIGH EFFICIENCY DESIGN

The geometry of the impeller and casing are generated through hydraulic design programmes. Whilst taking into account the fluid dynamics, hydraulic loss is minimised and pump efficiency maximised.

The MX-GG range operates at over 70% efficiency. Lower electricity costs also come from the use of high efficiency IE3 motors (where available). We also trim the impeller diameter to your required duty point, increasing process efficiency. Inverters are also available to achieve the ultimate efficiency in your system.



EX STOCK AVAILABLE



2 YEARS WARRANTY



ATEX ZONE 1/2 AVAILABLE



NEXT DAY DELIVERY



70% EFFICIENCY



PATENTED RUN DRY



CORROSION RESISTANCE



FLEXIBLE TO DESIGN SPEC

PLASTIC MAGNETIC DRIVE PUMPS

MX - GG PUMP RANGE

CHEMICAL PUMPING SOLUTIONS

END SUCTION, HORIZONTAL, **MAGNETIC DRIVE**, CENTRIFUGAL PUMPS

∞ RANGE CURVES

Pump curve for the magnetic drive AMX-GG ranges.

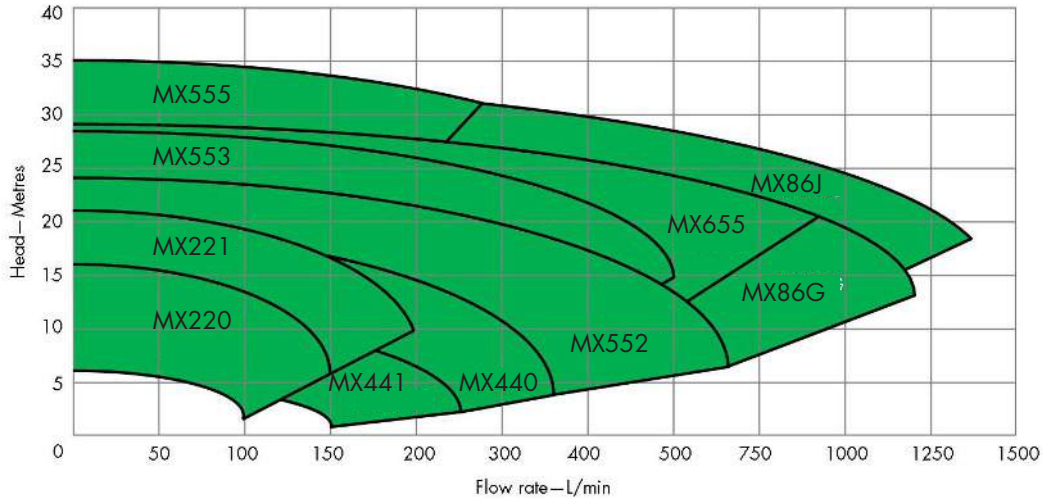

∞ TECHNICAL SPECIFICATION

MODEL	SUCTION (mm)	DIS-CHARGE (mm)	SPEED (rpm)	RATED CAPACITY (L/min)	RATED HEAD (m)	MAX CAPACITY (L/min)	MAX HEAD (m)	MOTOR OUTPUT (kW)
MX-GG 220	25	25	2900	100	12	150	16	0.37
MX-GG 221	25	25	2900	120	16	170	22	0.75
MX-GG 440	40	40	2900	100	10.9	250	12.3	0.4
MX-GG 441	40	40	2900	150	15.6	350	19.0	0.75
MX-GG 552	50	50	2900	200	20.6	450	24.4	1.5
MX-GG 552H	50	50	2900	100	25.8	300	27.6	1.5
MX-GG 553	50	50	2900	250	25.8	500	30.6	2.2
MX-GG 553H	50	50	2900	150	31.8	350	34.2	2.2
MX-GG 555	50	50	2900	250	30.2	500	35.0	4.0
MX-GG 653	65	50	2900	450	17.0	700	20.0	2.2
MX-GG 655	65	50	2900	500	25.0	800	27.6	4.0
MX-86G	80	65	2900	1000	20	1200	28	5.5
MX-86J	80	65	2900	1050	25	1350	33	7.5

MX - GG PUMP RANGE

CHEMICAL PUMPING SOLUTIONS

END SUCTION, HORIZONTAL, **MAGNETIC DRIVE**, CENTRIFUGAL PUMPS

∞ RANGE DIMENSIONS

NOTE:

1. The total length and weight of the pump will differ depending on the brand of the motor.
2. All dimensions are in mm.
3. Assembly tolerances are +/- 3mm.

Model range is full polypropylene range. Please see our website for more details on cast iron models.

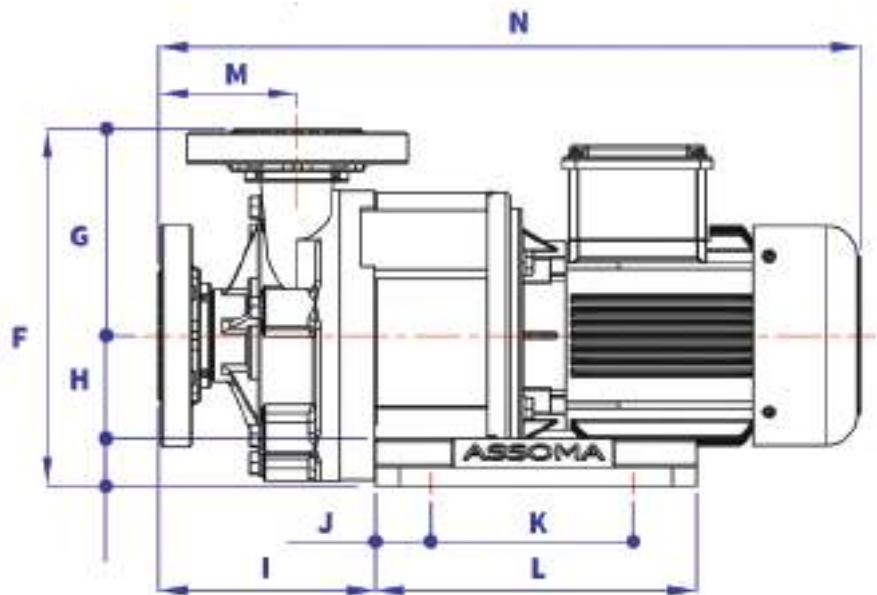
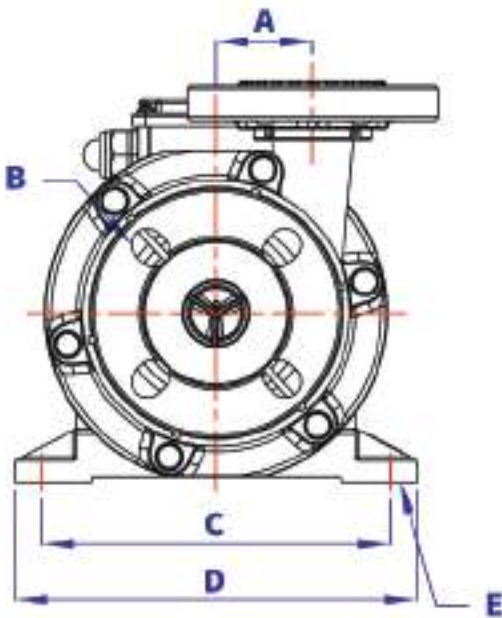
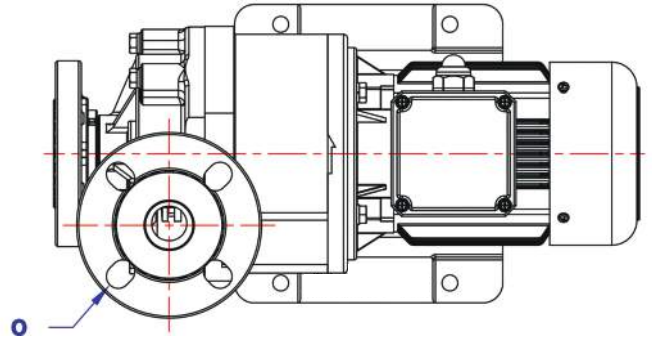

PLEASE ALLOW FOR MANUFACTURING TOLERANCES OF UP TO +/- 3MM

MODEL	A	B	C	D	E	F	G	H	I	J	K	L	M	N	O
MX 220	65	19	195	225	12	255	140	85	138	-	128	203	90	449	19
MX 221	65	19	195	225	12	255	140	85	138	-	128	203	90	473	19
MX 440	54	19	195	225	12	225.5	130.5	65	137	35	128	203	87.5	444	19
MX 441	72	19	195	225	12	257.5	142.5	85	153.5	-	128	203	105.5	489	19
MX 552	80	19	220	250	12	281.5	161.5	90	136	27	246	330	90	501	19
MX 553	80	19	220	250	12	281.5	161.5	90	136	27	246	330	90	526	19
MX 555	80	19	220	250	12	323.5	161.5	132	125	27	246	330	92.5	599	19
MX 653	80	19	220	250	12	331	169	132	131	27	246	330	92	540	19
MX 655	80	19	220	250	12	331	169	132	131	27	246	330	92	606	19

MX - GG PUMP RANGE

CHEMICAL PUMPING SOLUTIONS

END SUCTION, HORIZONTAL, **MAGNETIC DRIVE**, CENTRIFUGAL PUMPS

EXPLODED VIEW

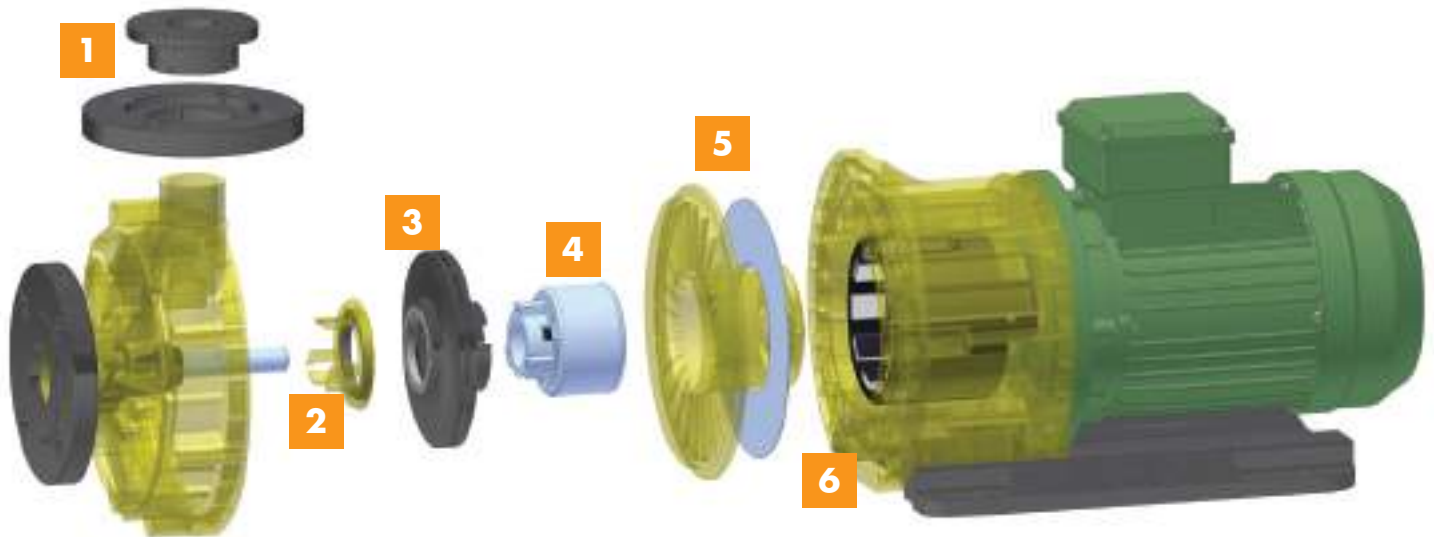

- 1 Flange assembly** - The orientation of the flange can be varied to match the corresponding boltholes to facilitate existing pipework. The new welded design also helps to eliminate leakage from potential flange deformation.
- 2 Patented buffer system** – the MX-GG range boasts a dynamic buffer system which absorbs vibration and shock caused by adverse operating conditions, increasing the mean time between servicing and reducing maintenance costs as a result.
- 3 High performance magnetic coupling** – using the latest magnetic analysis programmes to calculate magnetic torque and maximise utilisation, ensures sufficient torque margins to prevent de-coupling.
- 4 High efficiency flow design** – with over 70% operational efficiency, this helps reduce energy consumption and lowers energy costs.
- 5 Patented run dry design** – running a pump dry can halt any process. However the MX-GG range features run-dry protection built in, allowing the pump to run dry for an extending period of time, saving your process from total failure.
- 6 Integrated CAD Design** – the MX-GG has been designed to fit the modern requirements of a high efficiency process system. Constant research and development ensures that the MX-GG range is the industry standard in its field.

MA RANGE

CAPACITY 108 M³/HR
HEAD 80M
HEAVY DUTY DESIGN



MX RANGE

CAPACITY 800 L/M
HEAD 35M
RUN DRY DESIGN



M RANGE

CAPACITY 150 L/M
HEAD 10M
EX STOCK



INFORMATION

For more specific model curves, general arrangement drawings or exploded views of individual models, please ask

If you need 3D CAD models of the range, please contact one of our team and we will arrange for a copy to be sent to you by email.

MX - GG PUMP RANGE

CHEMICAL PUMPING SOLUTIONS

END SUCTION, HORIZONTAL, **MAGNETIC DRIVE**, CENTRIFUGAL PUMPS

PATENTED RUN DRY DESIGN

Unfortunately, errors can occur in a process that cause a pump to run dry. For a mechanically sealed pump this can cause an almost immediate failure to the seal. Some mag drive pumps are now available with special material bearings to prevent the onset of damage from running dry, but Assoma Mag Drive pumps go another step further with the patented circulation path for additional cooling.

Under normal operating conditions, the pumped liquid acts as lubrication between the rotating and stationary parts, and the heat generated by the rotational action is gently taken away by the circulating liquid. But when a pump is starved of liquid, these moving parts generate heat from friction and as the heat builds up, damage will occur.

However, with the Mag Drive range, a patented auxiliary circulation channel runs between the bearing and the magnet capsule. The pressure difference has a convection effect for cooling both the interior and exterior of the bearing thereby preventing the high temperature build up caused from dry running. The key point of this feature though, is that whilst the design allows for increased cooling, there is no reduction in pump efficiency.

We must point out that there are many ways to run a pump dry, and this design feature is in no way a failsafe method (you should question any pump manufacturer that does make this claim). It depends upon how (e.g. completely closed inlet valve, air lock, foot valve failure, etc) and for how long the pump is run dry, as to how long the Mag Drive range will run without damage being caused. For test reports or further information, please contact our engineers. If a pump is to be installed in an application where the pump is likely to see risks of dry running, then we would always recommend the installation of the PSP1 dry run monitor for additional peace of mind.

*This run dry design only applies to carbon/ceramic internal parts and not SSiC

Traditional circulation path

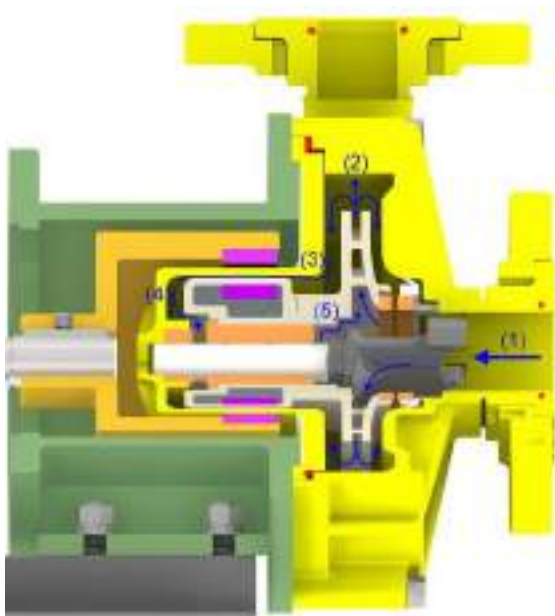

Assoma circulation path

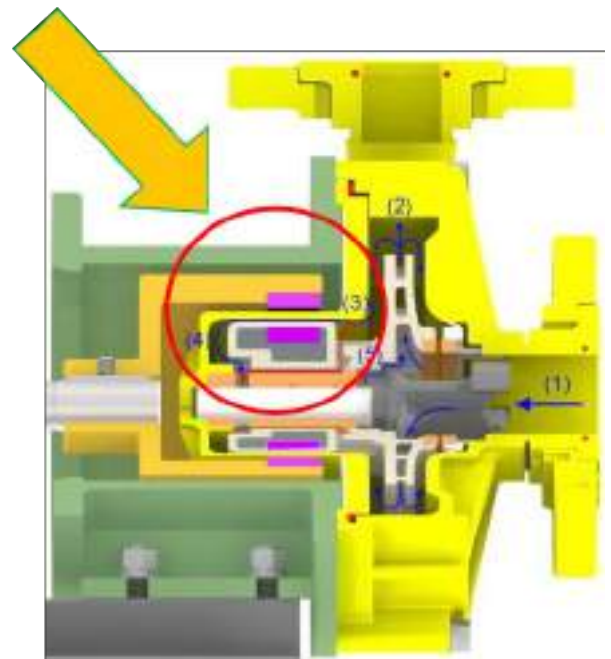

MX - GG PUMP RANGE

CHEMICAL PUMPING SOLUTIONS

END SUCTION, HORIZONTAL, **MAGNETIC DRIVE**, CENTRIFUGAL PUMPS

∞ PARTS LIST & MATERIAL CONSTRUCTION

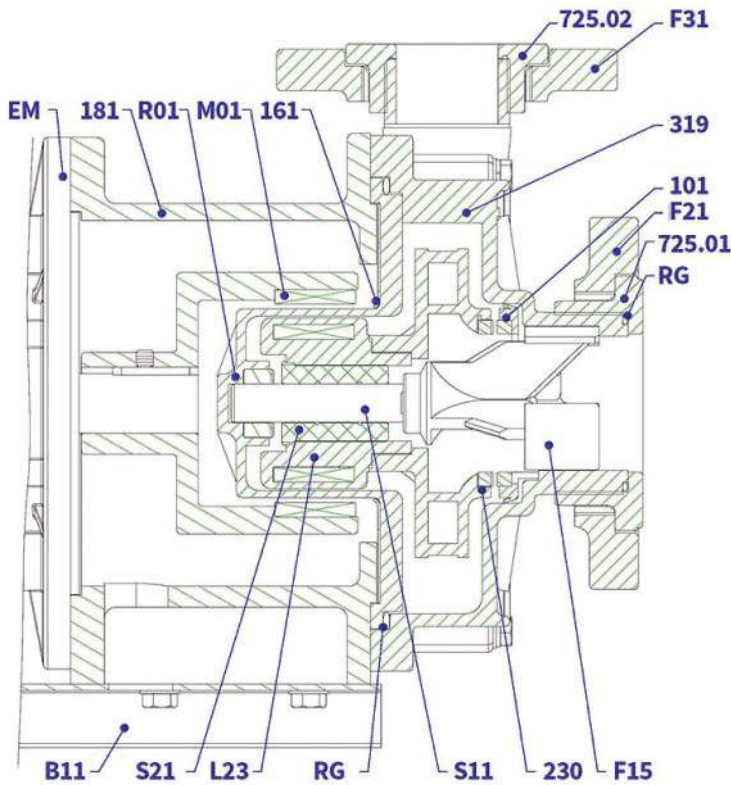

IMPROVED DESIGN FEATURES

The GG denotes the new design encompassing a polypropylene baseplate and adaptor. Compared to the older design of stainless steel and cast iron, polypropylene has a far greater chemical resistance, thus increasing the longevity of the entire pump in the harsh environments they can be exposed to.

The unique adjustable outer flange design remains, but the inner flange adaptor is now welded to the casing for greater strength and also removes any risk of leakage from o-ring deformation.



MATERIAL CODE	PART	ACV (ACE)	ARV (ARE)	SSV (SSE)	QUANTITY
101	PUMP CASING		PP + GF / ETFE + CF		1
161	BACKUP PLATE		SUS304		1
181	BRACKET		FC / PP + GF		1
230	IMPELLER WEAR RING	CARBON	PTFE + FILLER	SSiC	1
319	TRUST RING BUFFER	995 CERAMIC	995 CERAMIC	SSiC	1
725.01	INLET FLANGE ADAPTOR		PP + GF / ETFE + CF		1
725.02	OUTLET FLANGE ADAPTOR		PP + GF / ETFE + CF		1
B11	BASE PLATE*		SUS304 / PP + GF		1
EM	MOTOR		ALUMINIUM ALLOY /FC		1
F15	FRONT SHAFT SUPPORT		ETFE + CF		1
F21	INLET ADJUSTABLE FLANGE**		PP + GF / ETFE + CF		1
F31	OUTLET ADJUSTABLE FLANGE**		PP + GF / ETFE + CF		1
L23	MAGNET CAPSULE		PP / ETFE, Nd-Fe-B		1
M01	DRIVE MAGNET		Nd-Fe-B		1
R01	REAR CASING THRUST RING	995 CERAMIC	995 CERAMIC	SSiC	1
RG	GASKET	VITON /EPDM	VITON / EPDM	VITON / EPDM	1
S11	SHAFT	995 CERAMIC	995 CERAMIC	SSiC	1
S21	SLIDE BEARING	CARBON	PTFE + FILLER	SSiC	1

MX - GG PUMP RANGE

CHEMICAL PUMPING SOLUTIONS

END SUCTION, HORIZONTAL, **MAGNETIC DRIVE**, CENTRIFUGAL PUMPS

CASE STUDY - VANADIS POWER VANADIS POWER

“Vanadis power chose a pump that was able to provide a high operating efficiency whilst operating 24/7 with a hazardous yet highly valuable media.”

Engineers at Vanadis were looking for a reliable pump supplier to provide corrosion resistant pumps to be installed into the energy storage process. The pump is vital for the circulation of the electrolytes which create the kinetic energy.

Vanadis Power required 16 pumps that were able to pump from both the positive and negative electrolyte terminals into the membrane where the power is generated and stored into the back tank. A delicate process which requires a reliable and efficient pump for 24/7 recirculation.

We recommended and supplied the magnetic drive AMX555-GG pumps not only because they were the best fit for the duty required, but also for high efficiency and low running costs. The AMX-GG pumps were supplied in polypropylene components, including the baseplate and adaptor to enhance the corrosion resistant nature of the pump.



AIRBUS
GROUP

BASF
The Chemical Company

DOW

gsk

GE

AkzoNobel

Biffa

APPLICATIONS



CHEMICAL

Chemical applications include chemical transfer, dosing, re-circulation, filtration, fume scrubbing and tanker off-loading.



PETROCHEMICAL

Previous petrochemical installations include high temperature, high pressure, highly viscous applications as well as chemical injection, re-circulation, off-loading and solid handling.



WATER TREATMENT

Providing reliable process pumps to the UK's largest wastewater treatment providers, for chemical transfer, desalination, reverse osmosis, water treatment and tanker unloading.



PHARMACEUTICAL

Pharmaceutical companies have relied on Pumps to provide pumps for ATEX requirements, chemical injection, CIP pumping, solid handling, high viscous medias and highly toxic applications.



BIOFUELS

Fully ATEX certified process pumps for transfer of liquids in explosive atmospheres, solids handling, tanker unloading, recirculation and transfer.



ENERGY GENERATION

Pumps supplied for various energy generation applications, including wind turbine, solar, and Vanadium redox flow batteries.



MARINE

Centrifugal pumps supplied for various below deck applications including ballast water treatment, electrolysis, desalination and sea water cooling systems.

PLASTIC MAGNETIC DRIVE PUMPS